



J-TECH DIGITAL[®]

USER MANUAL^{V1.0}



160FT. 1080P HDMI EXTENDER OVER SINGLE CAT5E/6
JTD-229 | JTECH-EX2

J-TECH DIGITAL INC.
9807 EMILY LANE
STAFFORD, TX 77477
TEL: 1-888-610-2818



E-MAIL: SUPPORT@JTECHDIGITAL.COM

Scan the QR code below or visit <https://resource.jtechdigital.com/products/229> to view and access detailed digital resources regarding this unit.



Safety Instructions:

- Before using this product, please carefully read the following safety instructions to ensure its proper use and keep this manual for future reference:
- To prevent electric shock, do not attempt to open the product.
- Only qualified personnel should perform any repairs or maintenance.
- Always place the product on a stable, flat surface to prevent it from falling.
- Do not expose the product to water, moisture, or high-humidity environments to avoid the risk of damage.
- To prevent damage from direct sunlight or high temperatures, do not expose the product to such environments.
- Do not place the product near heat sources like radiators, heat registers, stove, or other heat-producing apparatus.
- Do not place any objects on top of the product to avoid damage.
- Use only the attachments and accessories specified by the manufacturer.
- During lightning storms or prolonged periods of disuse, unplug the power supply to prevent damage.

Table of Contents

1. Features	5
2. Specifications	5
3. Package Contents	5
4. Panel Description	6
5. Connecting and Operating	7
6. Maintenance	7
7. Warranty	7
8. Mail-In Services	7
9. Limited Warranty Limits and Exclusions	7

1. Features

- High-definition resolution up to Full HD 1080P 60Hz YUV 4:4:4
- Transmit over 160ft. CAT5E/6 without signal loss
- Supports 3D
- Supports LPCM up to 7.1 / 24bit / 192KHz

2. Specifications

Operating Temperature Range	0 - +40°C (32 0 +104°F)
Operating Humidity Range	5 – 90% RH (No condensation)
Input Video Signal	0.5 – 1.0 Volts P-P
Input DDC Signal	5 Volts P-P (TTL)
Video Formats	720P / 1080i / 1080P
Video Output	HDMI
Audio Formats	DTS-HD Master Audio, Dolby True-HD etc.
Transmission Distance	160ft. over single Cat5e/6
Power Consumption	2W (Maximum)
Dimensions (L x W x H)	TX: 79.3mm x 68mm x 16.5mm RX: 79.3mm x 68mm x 16.5mm
Net Weight	232g / 0.5lbs

3. Package Contents

- (1) x Transmitter
- (1) x Receiver
- (1) x DC 5V/1A Power Adapter
- (1) x User Manual

4. Panel Description

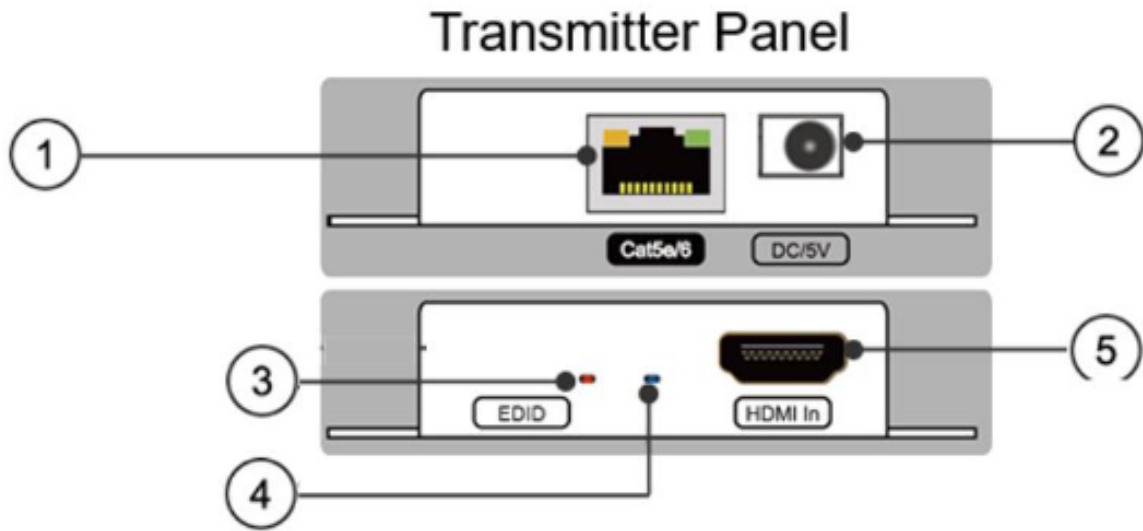

- 1. Ethernet Port
- 2. DC 5V/1A Power Port
- 3. Power Indicator
- 4. HDMI Indicator
- 5. HDMI Input Port

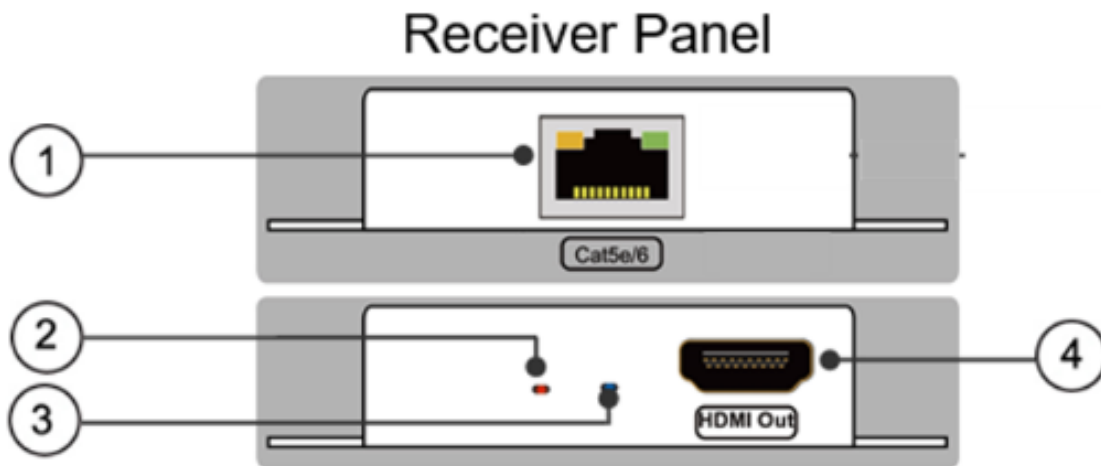

- 1. Ethernet Port
- 2. Power Indicator
- 3. HDMI Indicator
- 4. HDMI Output Port

5. Connecting and Operating

- Connect an HDMI signal source to the transmitter via HDMI cable
- Connect a CAT5e/6 cable to both the ethernet port on the transmitter and the receiver
- Connect a display via HDMI to the HDMI port on the receiver

6. Maintenance

Clean this unit with a soft, dry cloth. Never use alcohol, paint thinner, or benzene to clean.

7. Warranty

If your product does not work properly because of a defect in materials or workmanship, our company (referred to as “the warrantor”) will, for the length of the period indicated as below, “Parts and Labor (1) Year”, which starts with the date of original purchase (“Limited Warranty period”), at its option either (a) repair your product with new or refurbished parts, or (b) replace it with a new or a refurbished product. The decision to repair or replace will be made by the warrantor.

During the “Labor” limited warranty period, there will be no charge for labor. During the “Parts” warranty period, there will be no charge for parts. You must mail-in your product during the warranty period. This Limited Warranty is extended only to the original purchaser and only covers products purchased as new. A purchase receipt or other proof of original purchase date is required for Limited Warranty service.

8. Mail-In Service

When shipping the unit, carefully pack and send it prepaid, adequately insured, and preferably in the original carton. Include a letter detailing the complaint and provide a day time phone and/or email address where you can be reached.

9. Limited Warranty Limits and Exclusions

This Limited Warranty ONLY COVERS failures due to defects in material or workmanship, and DOES NOT COVER normal wear and tear or cosmetic damage. The Limited Warranty ALSO DOES NOT COVER damages which occurred in shipment, or failures which are caused by products not supplied by warrantor, or failures which result from accidents, misuse, abuse, neglect, mishandling, misapplication, alteration, faulty installation, set-up adjustments, mis-adjustment of consumer controls, improper maintenance, power line surge, lightning damage,

modification, or service by anyone other than a Factory Service center or other Authorized Servicer, or damage that is attributed to acts of God.

There are no express warranties except as listed under “Limited Warranty Coverage”. The warrantor is not liable for incidental or consequential damages resulting from the use of this product or arising out of any breach of this warranty. (As examples, this excludes damages for lost time, cost of having someone remove or re-install an installed unit if applicable, travel to and from the service, loss of or damage to media or images, data or other recorded content. The items listed are not exclusive but are for illustration only). Parts and service, which are not covered by this limited warranty, are your responsibility.



WWW.JTECHDIGITAL.COM

PUBLISHED BY J-TECH DIGITAL INC.

9807 EMILY LANE

STAFFORD, TX 77477

TEL: 1-888-610-2818

E-MAIL: SUPPORT@JTECHDIGITAL.COM